

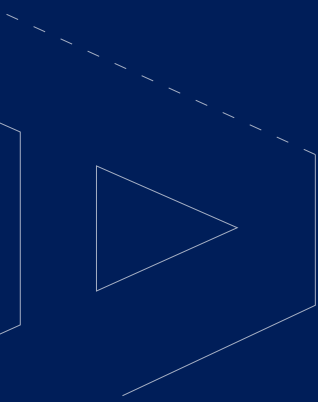

# USA<sup>TM</sup> LACROSSE



## LINING THE FIELD



UNIFIED MEN'S/WOMEN'S



## The Playing Area

### FIELD DIMENSIONS

The playing area shall be rectangular, 120 yards in length and 60 yards in width, marked with white or contrasting-colored lines. The long sides of the field shall be designated the sidelines and the shortest sides of the field designated as the end lines. A bold white or contrasting-colored line shall be marked through the center of the field perpendicular to the sidelines. This line shall be known as the center line and shall continue through any logos or other markings. See page 5 for diagram.

*Note: The optimal unified field size is 120 yards x 60 yards. Institutions may vary only the width of the field to between 53 1/3 yards to 60 yards to accommodate for existing field restrictions (existing football sidelines, etc).*

### LINE SIZES

- The Goal Line – shall be 2 inches wide
- The Center line – shall be 4 inches wide
- All other lines shall be between 2 – 4 inches wide (once size is determined it should be consistent on all other portions of the field)

### LINE MARKINGS

When measuring distances, it is important to know what part of the line WIDTH to start measurements; inside, outside, or center.

INSIDE Measurements: Side lines and End line [boundary lines]

OUTSIDE Measurements: Goal Crease, Goal/ Defensive Area lines, Wing Area lines

CENTER Measurements: Goal line and Center line

### CENTER CIRCLE

There is a circle, radius 30', in the center of the field. The Center line, parallel to the goal line, bi-sects this circle from sideline to sideline.

### CENTER "X" (FACE-OFF AREA)

A point on the center line, equidistant from each side, shall be marked with a 4-inch square that is a contrasting color and shall be designated the center of the field.

### GOAL AREAS

In both halves of the field, a line 40 yards long shall be marked, centered on the goal and parallel to and 25 yards from each goal line. Lines shall be drawn at right angles from the terminal points of these lines to connect them with the end lines.

### DEFENSIVE AREA LINES (RESTRAINING LINE)

A line shall be marked 25 yards away from and parallel to each goal line. This line coincides with the 40-yard portion of the goal-area line and is known as the restraining line and shall extend from sideline to sideline.

### GOAL LINE

A 2-inch line shall be drawn between the goal posts to indicate the plane of the goal, and it shall be designated the goal line. The goals shall be centered between the sidelines and placed 15 yards from each end line.



## GOAL CREASE

Goal creases around each goal shall be a plainly marked circle. The area within the crease shall not be painted. This circle shall be marked by using the midpoint of the goal line as the center and drawing a circle with a radius of 9 feet. The goal-crease area is the circular surface about each goal within and including the goal-crease like itself.

## ARC AND FAN FOR UNIFIED FIELD

(See diagram on page 4 for instructions)

## BELOW GOAL MARKINGS

Two small circles (dots) 4-6 inches in diameter must be added to the field behind each goal. The circles should mirror each other, 5 yards from the marks on the goal line extended. They shall be marked in the direction towards the end line and measured in a line perpendicular to the goal line extended.

## WING AREA

Lines parallel to the sidelines shall be marked on each side of the field 20 yards from the center of the field and extending 10 yards on each side of the center line. The areas between these line segments and the sidelines and confined within the extremities of those line segments shall be designated as wing areas.

## TABLE AREA

Where physically possible, the scorer's table should be placed at least 6 yards from the sideline at the center line. Two lines perpendicular to the sideline, shall be drawn on either side of the center line 10 yards from the center line and extending past the scorer's table. The area bounded by the sideline, the two lines perpendicular to the sideline and the scorer's table shall be referred to as the table area.

## PENALTY AREA

The penalty area shall be located within the table area immediately in front of the scorer's table.

## COACHES' AREAS

The coaches' area shall be located on either side of the table area. Each coaches' area shall extend from the table area 15 yards parallel to the sideline. It shall be bounded by the sideline, the table area, a dotted line 6 yards from and parallel to the sideline, and a dotted line extending from the sideline, parallel to and 15 yards from the table-area line.

## TEAM AREAS

The team areas shall be on either side of the table area located behind the Coaches' Areas. Each team area shall extend from the table area 15 yards parallel to the sideline. Each team area shall be bounded on the field side by the coaches' areas. Benches for the competing teams shall be placed on either side of the scorer's table at least 10 yards from the table and where physically possible, at least 10 yards from the sideline, parallel to the sideline.

## FIELD MARKERS

Soft Flexible cones or pylons of red or orange color should be placed at the outside edge of each of the four corners of the field and at the outside edge of the intersection of the center line and the sideline opposite the table area. Only cones should be placed at the intersections of the table-area line and sideline, directly in front of the table area.

# MAKING THE SIDELINE PERPENDICULAR TO THE ENDLINE

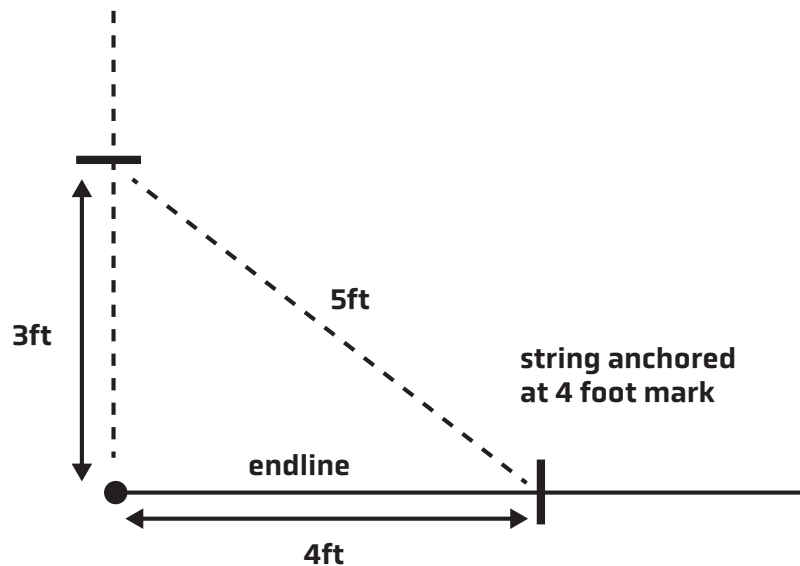

## 3-4-5-TRIANGLE RULE

After creating the endline of the field, the next step is to create two sidelines perpendicular to it. One of the easiest ways to do this is to use a mason's trick for making a square corner and a little bit of Geometry class. Mark a location on the endline four feet or yards (choose one unit and use it throughout) from the end of the endline toward the center of the endline. Anchor a five foot or yard piece of string at this location. Anchor a second piece of string three foot or yards long at the end of the endline where it meets the sideline.

These two pieces of string will intersect three feet or yards up the sideline when it is perpendicular to the endline. Do this for both sidelines and when you measure off the length of the field, they should still be the width of the endline a part. Using the longer string lengths in yards should offer more accurate results.

## STEPS TO PAINTING A UNIFIED LACROSSE FIELD

1. Paint the first end line
2. Use the 3-4-5-triangle rule to make your first sideline that is terminal to the endline
3. Paint the second end line that connects to the sideline
4. Paint the last sideline
5. Paint the goal line and goal crease
6. Paint the arc and fan
7. Paint the restraining lines (Goal Area line extended to each sideline)
8. Paint the sides of the Goal Area from the restraining line to the end line (20-yards, on each side, from the center of the field and parallel to the sidelines).
9. Paint the Center Line and Center Circle
10. Paint the wing areas perpendicular to the center line
11. Paint the table area
12. Paint the coaches and team areas last

## DIRECTIONS FOR 8 METER ARC AND 12 METER FAN

### Unified Field

#### 8 METER ARC

1. The goal circle is made first. The goal circle is a circle, radius 9' measured from the center of the goal line (D) to the outer edge of the goal circle line. The goal circle line shall be 2"-4" (5cm-10.1cm) wide.
2. The goal line should be 2" to align with the goalposts of the goal cage.
3. Run string from the point (A) on the back of the goal circle that is perpendicular to the goal line at its center, to the points on goal circle (B), where if the goal line were extended would intersect the circle. Extend and mark these lines (45-degree angle) from the goal circle (B) 28'-3" (8.58m) to point C.
4. To mark the curve of the arc, measure from the center of the goal line (D) 35' 4" to G connecting the sidelines. The arc will now be 8 meters from the circle.
5. The center hash mark 1' (30.5cm) on the 8-meter arc shall be measured from the center of and perpendicular to the goal line (35' 4"). The other hash marks will be measured 4, 8, and 12 meters respectively from either side of the center hash mark. Two additional hash marks will be made 8 meters from the goal circle, perpendicular to the goal line extended.

#### 12 METER FAN

Inscribe a semi-circle (E) from the center of the goal line (D) 48' 3". The flat side of the semi-circle should be marked from the points on the goal circle (B) to the semi-circle.

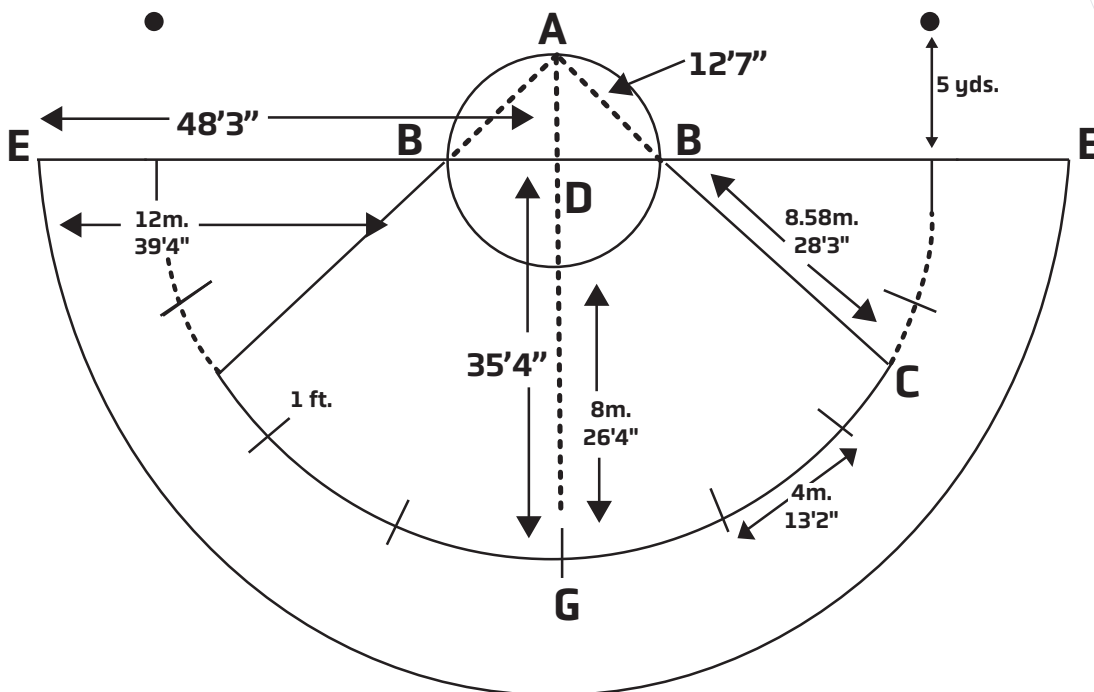

# UNIFIED FIELD DIAGRAM

